

UNCONTROLLED DOCUMENT

29F0330-2SR-10

PHYSICAL DIMENSIONS:

A	8.33 [.328]	\pm 0.13 [.005]
B	10.87 [.428]	\pm 0.15 [.006]
B1	13.46 [.530]	MAX
C	6.35 [.250]	\pm 0.10 [.004]
C1	7.11 [.280]	MAX
D	7.62 [.300]	\pm 0.13 [.005]
E	2.54 [.100]	\pm 0.13 [.005]

WIRE DIMENSIONS:

T ₁	2.64 [.104]	\pm 0.25 [.010]
T ₂	0.64 [.025]	TYP
T ₃	0.38 [.015]	TYP

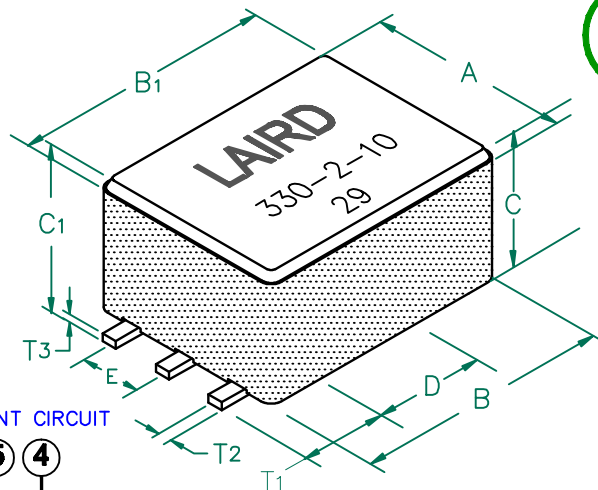

ELECTRICAL CHARACTERISTICS:			
Z @ 100MHz (Ω)	DCR (Ω)	Rated Current	
Nominal	200		
Minimum	150		
Maximum	250	0.01	9,000 mA

- NOTES: UNLESS OTHERWISE SPECIFIED
1. TAPED AND REELED per CURRENT EIA SPECIFICATION, 13" REELS, 450 PCS/REEL.
 2. COMPONENTS SHOULD BE ADEQUATELY PREHEATED BEFORE SOLDERING.
 3. REF. CARRIER TAPE SPEC.# CART330-23.
 4. TERMINATION FINISH IS 100% TIN.
 5. THIS PART HAS NO PIN POLARITY.

EQUIVALENT CIRCUIT

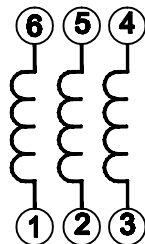

LAND PATTERNS FOR REFLOW SOLDERING

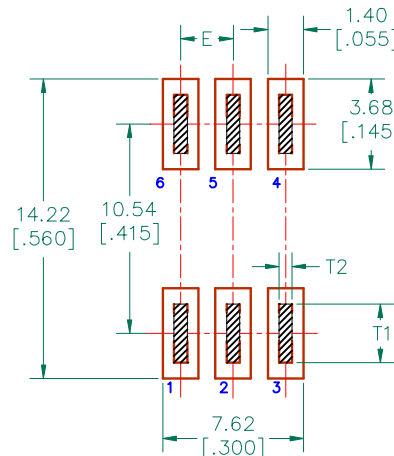

RECOMMENDED SOLDERING CONDITIONS

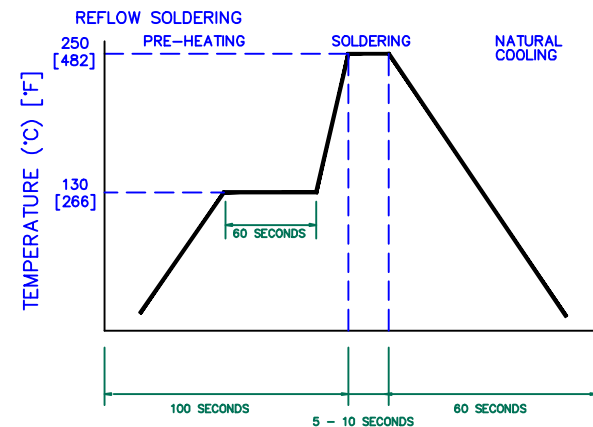

|Z| , R, AND X vs. FREQUENCY

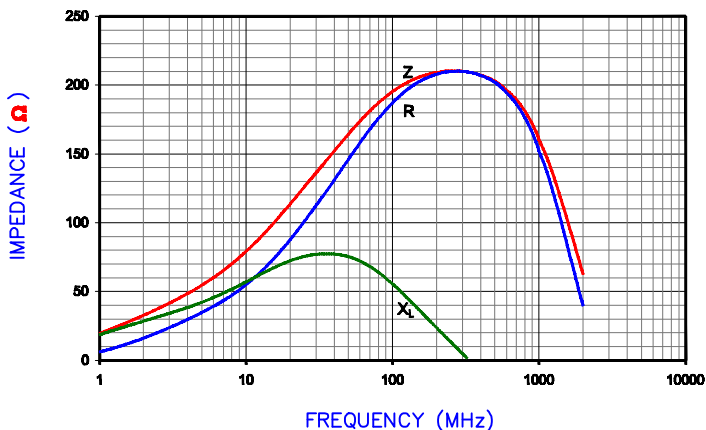

Z **R** **X_L**

AGILENT E4991A RF Impedance/Material Analyzer
HP 16194A Test Fixture

DIMENSIONS ARE IN mm [INCHES]				This print is the property of Laird Tech. and is loaned in confidence subject to return upon request and with the understanding that no copies shall be made without the written consent of Laird Tech. All rights to design or invention are reserved.			
D	UPDATE COMPANY LOGO ADD EQUIV. CIRCUIT CHG KAPTON LABEL	10/27/08	JRK	PROJECT/PART NUMBER: 29F0330-2SR-10	REV D	PART TYPE: FERRITE ASSEMBLY	DRAWN BY: JRK
C	UPDATE COMPANY LOGO	05/03/07	JRK	DATE: 04/30/04	SCALE: NTS	SHEET: 2 of 3	
B	CORRECT REV BLOCK mm [INCHES]	10/20/06	JRK	CAD # 29F0330-2SR-10-D-2	TOOL # H0331		
A	ORIGINAL DRAFT	04/30/04	JRK				
REV	DESCRIPTION	DATE	INT				

